

Automatic Roof Door Vents

Features

- UL Listed for use as an automatic smoke vent
- FM Approved as an automatic door vent for use in high-expansion foam systems
- Available in multiple sizes and corrosion-resistant materials, including galvanized steel and aluminum
- Designed to open against snow and wind load and lock in the open position
- Doors are fully insulated and curbs supplied with permanent gaskets for weather-resistant performance

Application

The CHEMGUARD Automatic Roof Door Vent is intended for use with the CHEMGUARD Water Powered High-Expansion Foam Generators. Automatic door vents are required when installing an air intake to facilitate supplying outside air to CHEMGUARD Water Powered High-Expansion Foam Generators (see data sheet Form No. CG-2016005, latest revision). The doors are weather tight and are normally closed until actuated either by foam solution pressure supplied to the high-expansion foam generators or thermal release of a UL Listed fusible link.

Description

CHEMGUARD Automatic Roof Door Vents utilize gas spring operators with integral dampers for controlled opening of the doors to prevent damage to the doors or building. The doors are held closed by a latching mechanism which utilizes a separate latching point for each door. The latch is held in place by a UL Listed 165 °F (74 °C) fusible link and releases automatically when the fusible link melts or is disengaged by a hydraulic cylinder operated by foam solution pressure supplied when the high-expansion foam system operates. The latching mechanism can also be released manually using interior or exterior pull cables. Once open, the door covers are locked in place by the hold open feature of the gas spring operators.

Assembly Materials

The covers and frame are available in either 14 gauge G-90 galvanized steel or 11 gauge aluminum.

Door Covers

The door covers utilize a hollow design with 1 in. (25.4 mm) of fiberglass insulation and are internally reinforced to support up to a maximum 40 psf (195 kg/m²) live load.

Roof Curb

Overall Height: 12 in. (305 mm)

Flange: 3 1/2 in. (89 mm) with 7/16 in. (11 mm) mounting holes

Insulation: 1 in. (25 mm) fiberboard insulation

Gasket: Extruded EPDM, permanently adhered

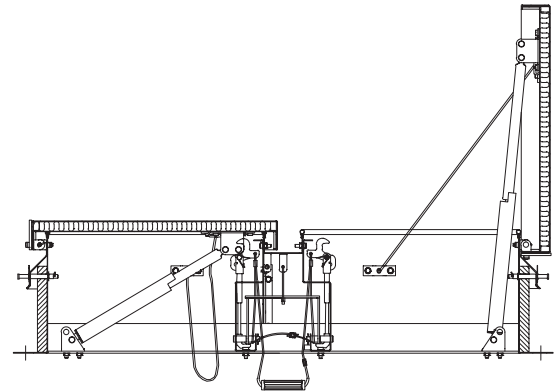

010288a

Finish

Galvanized steel assemblies are provided with an alkyd base red oxide primer. Aluminum assemblies are provided with a mill finish.

Latching Mechanism and Automatic Operation

The latching mechanism may be automatically operated either by release of a UL Listed 165 °F (74 °C) fusible link or operation of the hydraulic cylinder. The hydraulic cylinder requires a minimum of 40 psi (2.8 bar) to disengage the fusible link. The latching mechanism may also be manually released by operation of either the internal or external manual pull cables. The latching mechanism is designed to hold the covers closed against a maximum 90 psf (438 kg/m²) wind uplift force.

Operational Loading Limits

CHEMGUARD Automatic Roof Door Vents are designed to open against a maximum 10 psf (49 kg/m²) combined snow and wind load.

Hardware

CHEMGUARD Automatic Roof Door Vents open utilizing gas spring operators with integral dampers to control the speed of the opening doors. The gas spring operators are provided with a powder coated body and chromate plated inner rod. All other components are either zinc plated/chromate sealed or galvanized.

Approvals

CHEMGUARD Automatic Roof Door Vents carry the following listings and approvals:

- UL Listed by the manufacturer as an automatic smoke vent (UL 793 and UL 790 Class A).
- FM Approved for use in high-expansion foam systems (FM 5130).

Ordering Information

Part Number	Description	Free Vent/ Intake Area		Shipping Weight	
		(ft ²)	(m ²)	lb	(kg)
703700	48 in. x 48 in. Aluminum Automatic Roof Door Vent Kit including Actuator Assembly	16	(1.49)	265	(120)
703701	48 in. x 48 in. Galvanized Steel Automatic Roof Door Vent Kit including Actuator Assembly	16	(1.49)	372	(169)
703702	60 in. x 60 in. Aluminum Automatic Roof Door Vent Kit including Actuator Assembly	25	(2.32)	335	(152)
703703	60 in. x 60 in. Galvanized Steel Automatic Roof Door Vent Kit including Actuator Assembly	25	(2.32)	700	(318)
703704	Replacement Actuator Assembly	n/a		5	(2.2)

Note: The standard door vents offered are to be installed on flat roof types only. Contact Johnson Controls Technical Services if vents are to be installed on a Raised Rib or other type roof.

Ductwork required between the CHEMGUARD Automatic Roof Door Vent and the high-expansion foam generator(s) is not included and must be designed and installed by qualified personnel.

Installation

CHEMGUARD Automatic Roof Door Vents should ideally be installed directly above vertically installed high-expansion foam generators or as close as possible when the high-expansion foam generators are installed in the horizontal orientation (see Figures 1 to 6). Automatic Roof Door Vents are required to be connected to the generator by ductwork to help ensure air supplied to the generator is from outside the hazard area. The design and installation of the ductwork shall be completed by qualified personnel and shall minimize friction loss at the high-expansion foam generator. Contact Johnson Controls Technical Service for complete installation instruction.

For automatic operation utilizing the actuator assembly, the actuator must be connected to the foam solution piping, preferably near the inlet of the high-expansion foam generator. 1/4 in. copper tubing, brass pipe, or stainless steel pipe can be used to connect the foam solution piping to the strainer inlet of the actuator assembly. See Figures 7 to 9 for details of the actuator assembly.

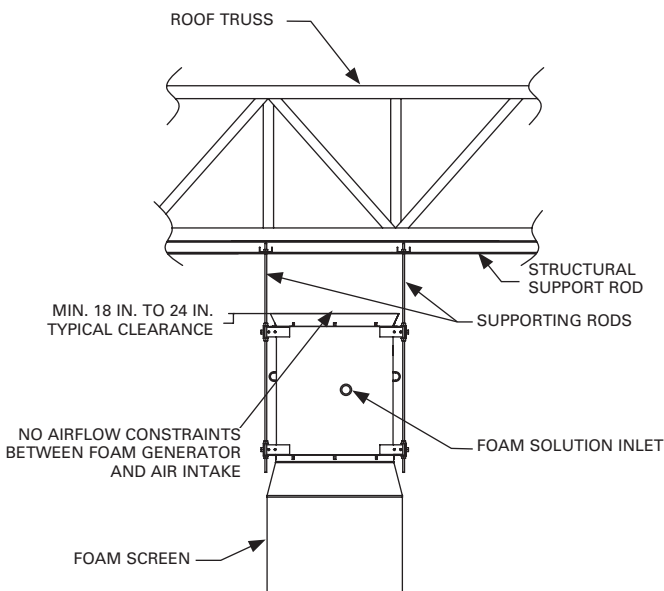

FIGURE 1
FRONT VIEW OF FOAM GENERATOR IN VERTICAL MOUNT POSITION WITHOUT AIR INTAKE

009637

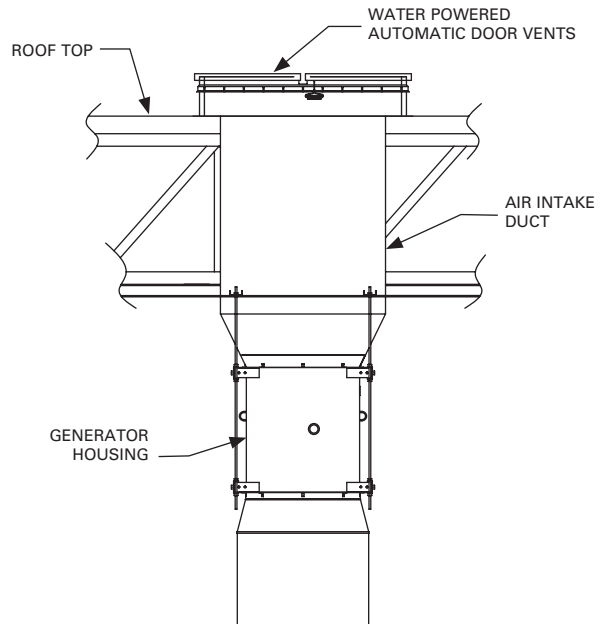

FIGURE 2
FRONT VIEW OF FOAM GENERATOR IN VERTICAL MOUNT POSITION WITH AIR INTAKE

009638

Installation (Continued)

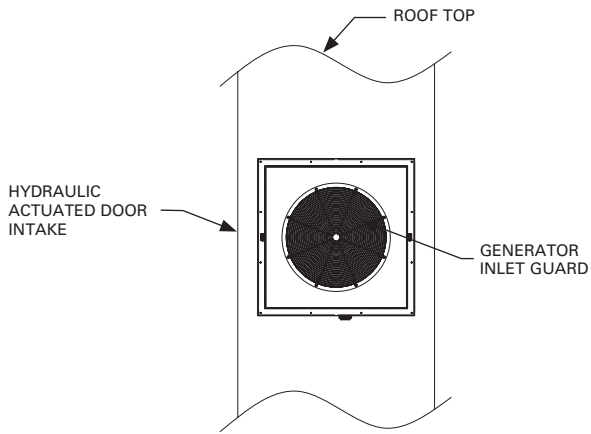

FIGURE 3
ROOFTOP VIEW OF FOAM GENERATOR IN VERTICAL MOUNT POSITION WITH AIR INTAKE

009639

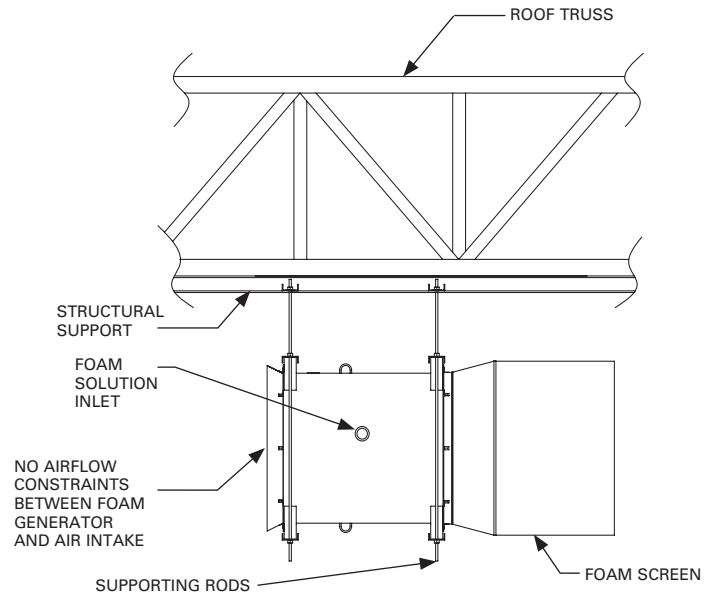

FIGURE 4
FRONT VIEW OF FOAM GENERATOR IN HORIZONTAL MOUNT POSITION WITHOUT AIR INTAKE

009634

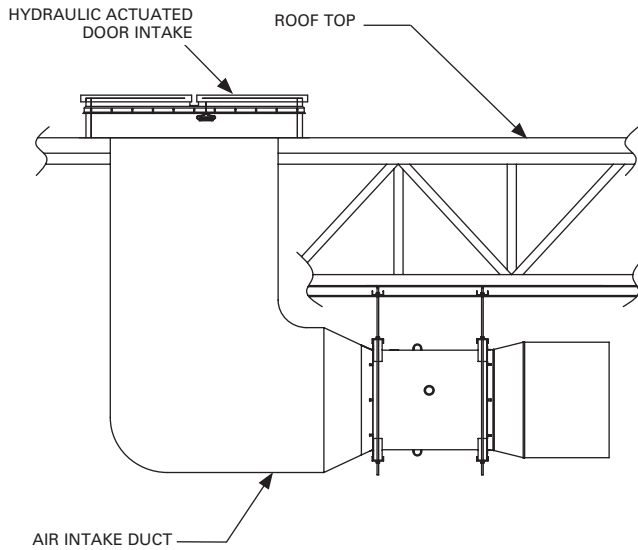

FIGURE 5
FRONT VIEW OF FOAM GENERATOR IN HORIZONTAL MOUNT POSITION WITH AIR INTAKE

009635

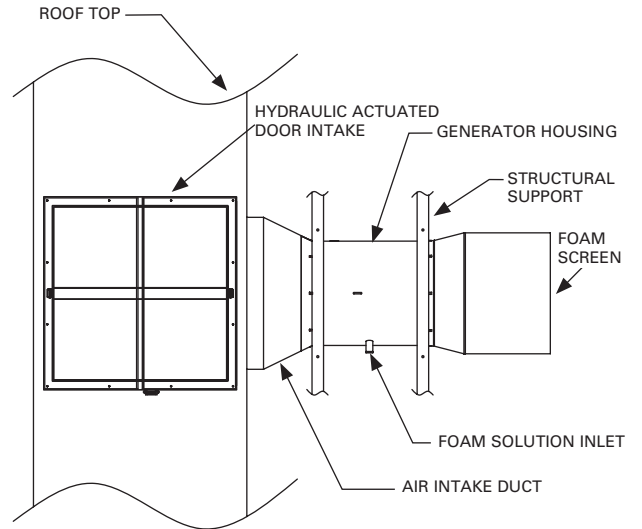

FIGURE 6
ROOFTOP VIEW OF FOAM GENERATOR IN HORIZONTAL MOUNT POSITION WITH AIR INTAKE

009636

Installation (Continued)



FIGURE 7
ACTUATOR ASSEMBLY IN THE SET UP POSITION
010291



FIGURE 8
ACTUATOR AND LATCH MECHANISM
010290

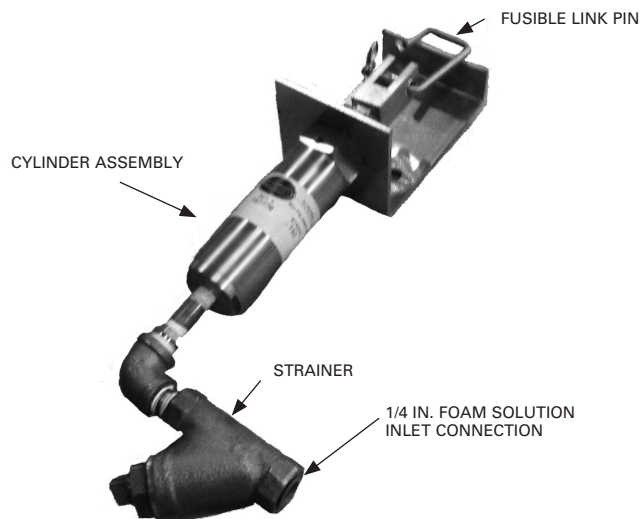
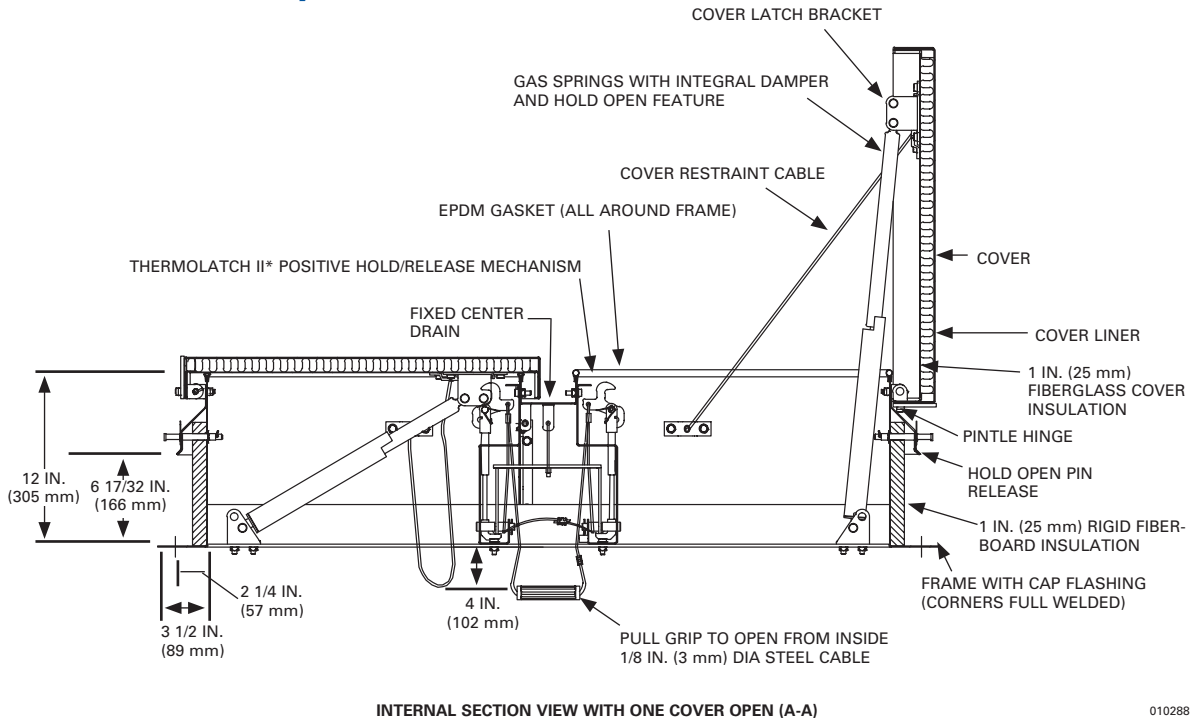
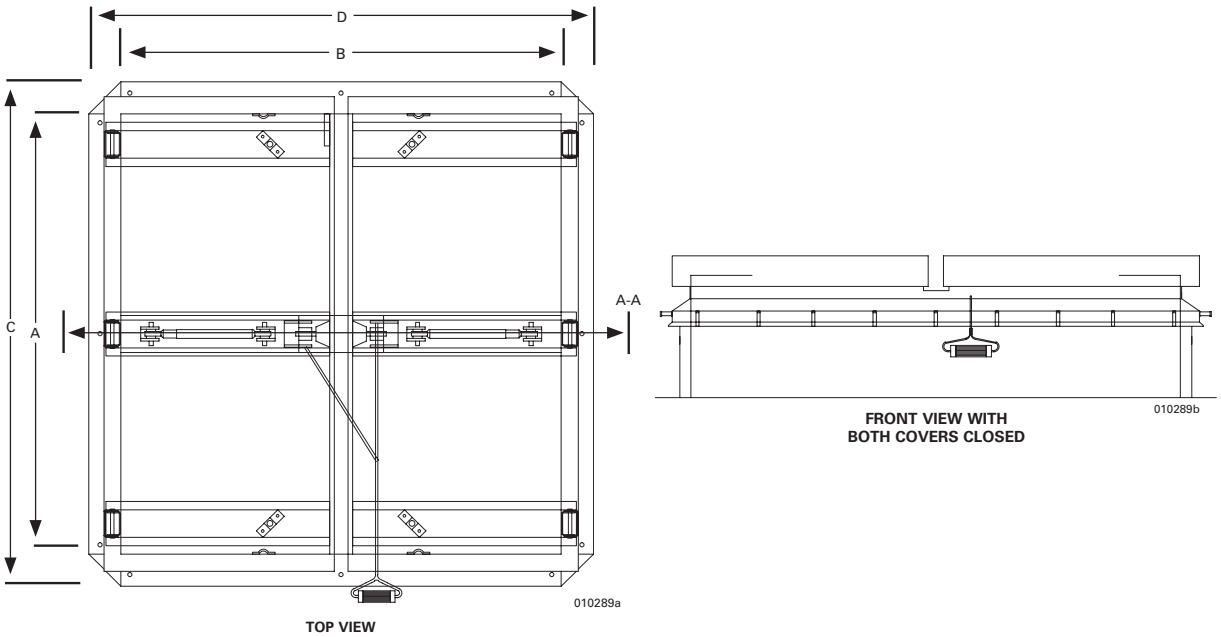

FIGURE 9
ACTUATOR ASSEMBLY WITH STRAINER
010292

General Assembly



010288



010289a

010289b

Part No.	Item	Qty.	A in. (m)	B in. (m)	C in. (m)	D in. (m)	Weight lb (kg)	Size Louver door with water powered actuator in. (m)	Material
703700	1	1	48 (1.2)	48 (1.2)	55 (1.4)	55 (1.4)	265 (120)	48 x 48 (1.2 x 1.2)	Aluminum
703701	2	1	48 (1.2)	48 (1.2)	55 (1.4)	55 (1.4)	372 (169)	48 x 48 (1.2 x 1.2)	Steel painted
703702	3	1	60 (1.5)	60 (1.5)	67 (1.7)	67 (1.7)	335 (152)	60 x 60 (1.5 x 1.5)	Aluminum
703703	4	1	60 (1.5)	60 (1.5)	67 (1.7)	67 (1.7)	700 (318)	60 x 60 (1.5 x 1.5)	Steel painted

Venting Requirements For High-Expansion Foam Systems in Enclosed Spaces

High-expansion foam systems may be installed to utilize air from outside or, with the approval of the Authority Having Jurisdiction, inside the hazard area. **Note:** Only outside air is allowed for FM Approved high-expansion foam systems.

When using outside air, a system of ducts and vents, either through the wall or roof of the structure, is required to supply fresh air to the high-expansion foam generators. If the high-expansion system discharges into an enclosed space, and the system is equipped with a fresh air inlet system, the efficiency of the high-expansion foam generating system will be inhibited due to a slight over-pressurization of the enclosed space.

As the high-expansion foam system discharges into an enclosed space with air from outside, a volume of air equal to the discharge of the high-expansion foam generators is introduced into the space. This volume of air can cause a significant increase of air pressure inside the enclosed space, and if this occurs, the efficiency of the generators will decrease as the air pressure increases.

It is recommended in high-expansion foam systems with outside air supplied to the generators, high level vents be installed to prevent pressurization of the enclosed space. These vents should operate automatically upon actuation of the system or include some other normally open feature, and should be approximately the same area as the inlet vents to the foam generators. In no case, without complete air flow calculations by a licensed HVAC engineer, should the exhaust vents be less than 80% of the total area of inlet vents to the high-expansion foam generators.

Ventilation should be in accordance with NFPA 11-2016, Section 6.12.4.1.2 - Ventilation:

- **6.12.4.1.2.1:** Where outside air is used for foam generation, high-level venting shall be provided for air that is displaced by the foam.
- **6.12.4.1.2.2:** Venting velocity shall not exceed 305 m/min (1000 ft/min) in free air.
- **6.12.4.1.2.3:** The required venting shall consist of suitable openings, either normally open or normally closed and arranged to open automatically when the system operates.
- **6.12.4.1.2.4:** Where design criteria demand exhaust fans, they shall be approved for high temperature operation and installed with consideration for protection of switches, wiring, and other electrical devices to ensure equal reliability of exhaust fan performance. Operation of the fans shall not compromise foam generator operations.
- **6.12.4.1.2.5:** Where forced-air ventilating systems interfere with the proper buildup of foam, they shall be automatically shut down or closed.

For additional information, contact Johnson Controls Technical Services.

Note: The converted values in this document are provided for dimensional reference only and do not reflect an actual measurement.

*THERMOLATCH II is a trademark of The Bilco Company.

CHEMGUARD, JET-X, and the product names listed in this material are marks and/or registered marks. Unauthorized use is strictly prohibited.